

CODE 3003

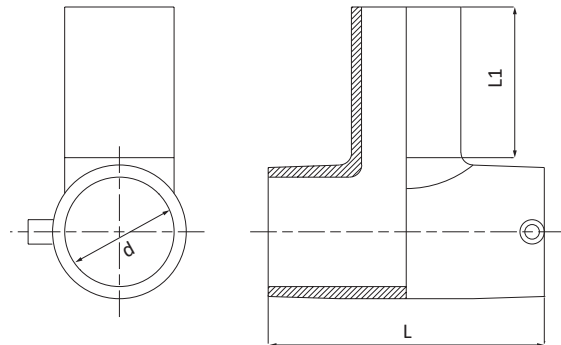

Ti intermedio
PE100 - S5 Gas - PN 16 20°C



PE100 - SDR11 - S5
ACQUA: PFA (PN)=16 bar 20°C
GAS: MOP=10 bar; In Italia MOP=5 bar (D.M. 24/11/84, D.M. 16/4/2008 e successive modifiche)
Per il tempo di saldatura da utilizzare con tubo SDR26 contattare direttamente Unidelta.

CODE	DIM dx dx dx [mm]	L [mm]	L1 [mm]	W-SDR	PACK				
					RIF. 10	RIF. 11	RIF. 12	RIF. 13	Sfusi
3003021000001	20x20x20	87	54	≤ 11	-	25	-	-	-
3003026000001	25x25x25	96	54	≤ 11	-	20	-	-	-
3003033000001	32x32x32	104	58	≤ 11	-	12	-	-	-
3003041000001	40x40x40	115	59	≤ 17	-	8	-	-	-
3003051000001	50x50x50	131	67	≤ 17	-	-	-	12	-
3003064000001	63x63x63	150	77	≤ 17	-	-	-	8	-
3003076000001	75x75x75	174	86	≤ 17	16	-	-	-	-
3003091000001	90x90x90	201	98	≤ 17	10	-	-	-	-
3003111000001	110x110x110	237	104	≤ 17	6	-	-	-	-
3003125000001	125x125x125	274	141	≤ 17	-	-	-	-	1
3003140000001	140x140x140	305	145	≤ 17	-	-	-	-	1
3003160000001	160x160x160	340	151	≤ 17	-	-	-	-	1
3003180000001	180x180x180	360	162	≤ 17	-	-	-	-	1
3003200000001	200x200x200	358	173	≤ 17	-	-	-	-	1 <i>New</i>
3003225000001	225x225x225	406	184	≤ 17	-	-	-	-	1 <i>New</i>
3003250000001	250x250x250	448	195	≤ 17	-	-	-	-	1 <i>New</i>